

# GCL-P6/72xxx

HIGH EFFICIENCY  
MULTICRYSTALLINE MODULE

**GCL-P6/72 310-345 Watt**

**345<sup>W</sup>**  
(±3%)

MAXIMUM POWER OUTPUT

**17.8%**

MAXIMUM MODULE EFFICIENCY

## Trust GCL to Deliver Reliable Performance Over Time

- World-class manufacturer of crystalline silicon photovoltaic modules
- Fully automatic facility and world-class technology
- Rigorous quality control to meet the highest standard:  
ISO9001:2008, ISO 14001: 2004 and OHSAS: 18001 2007
- Long term reliability tests
- 2\*100% EL inspection ensuring defect-free modules



Ideal choice for large scale ground installation



High conversion efficiency due to top quality wafer and advanced cell technology



Optimized system performance by module level current sorting



Special cell process ensures great performance in low irradiance environment



Additional yield and easy maintenance with high transparent self-cleaning glass

## LINEAR PERFORMANCE WARRANTY

10 Years Product Warranty

25 Years Linear Power Warranty

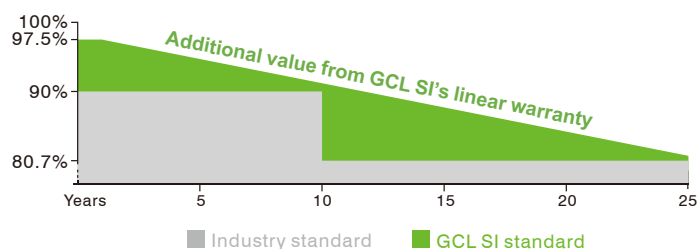

Additional insurance backed by Swiss RE



Bringing Green Power to Life

# GCL-P6/72xxx

HIGH EFFICIENCY MULTICRYSTALLINE MODULE

## MODULE DIMENSION

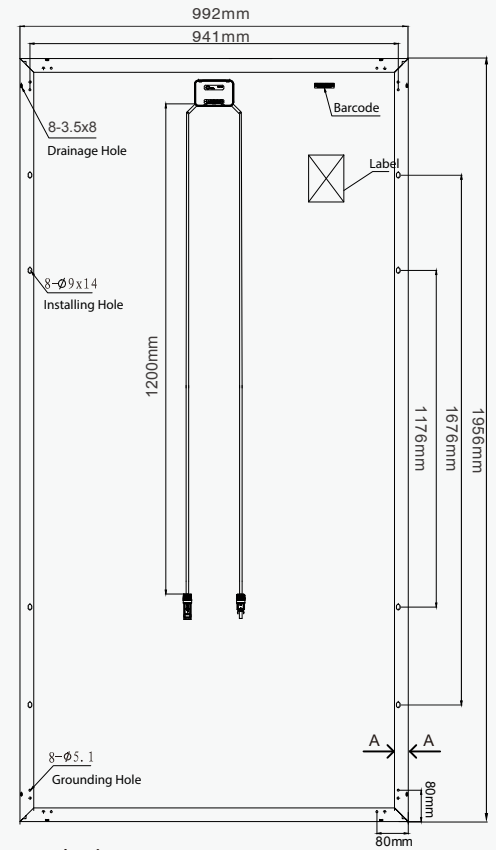

Back View

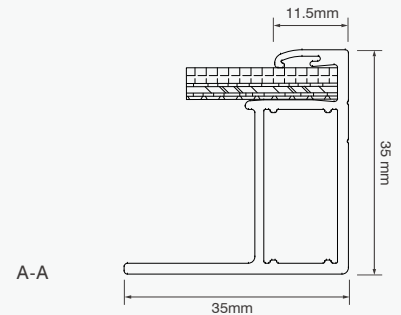

A-A

### ELECTRICAL SPECIFICATION (STC)

TYPE (STC)	GCL-P6/72 310	GCL-P6/72 315	GCL-P6/72 320	GCL-P6/72 325	GCL-P6/72 330	GCL-P6/72 335	GCL-P6/72 340	GCL-P6/72 345
Maximum Power $P_{max}$ (W)	310(±3%)	315(±3%)	320(±3%)	325(±3%)	330(±3%)	335(±3%)	340(±3%)	345(±3%)
Maximum Power Voltage $V_m$ (V)	37.00	37.20	37.40	37.60	37.80	38.00	38.20	38.90
Maximum Power Current $I_m$ (A)	8.38	8.47	8.56	8.64	8.73	8.82	8.90	8.87
Open Circuit Voltage $V_{oc}$ (V)	45.40(±3%)	45.60(±3%)	45.80(±3%)	46.00(±3%)	46.20(±3%)	46.40(±3%)	46.60(±3%)	47.30(±3%)
Short Circuit Current $I_{sc}$ (A)	8.99(±4%)	9.08(±4%)	9.17(±4%)	9.24(±4%)	9.33(±4%)	9.41(±4%)	9.49(±4%)	9.33(±4%)
Module Efficiency (%)	16.0	16.2	16.5	16.7	17.0	17.3	17.5	17.8
Power Output Tolerance $P_m$ (W)	0~+5							

Values at Standard Test Conditions STC (Air Mass AM1.5, Irradiance 1000W/m<sup>2</sup>, Cell Temperature 25°C).

### ELECTRICAL DATA (NOCT)

Maximum Power $P_{max}$ (W)	231.88	234.96	238.05	241.17	245.00	248.86	252.75	256.68
Maximum Power Voltage $V_m$ (V)	34.10	34.30	34.50	34.70	34.90	35.10	35.30	35.60
Maximum Power Current $I_m$ (A)	6.80	6.85	6.90	6.95	7.02	7.09	7.16	7.21
Open Circuit Voltage $V_{oc}$ (V)	42.20	42.40	42.60	42.80	42.90	43.10	43.30	44.00
Short Circuit Current $I_{sc}$ (A)	7.31	7.36	7.41	7.46	7.53	7.60	7.66	7.76

NOCT: Irradiance at 800W/m<sup>2</sup>, Ambient Temperature 20°C, Wind Speed 1m/s.

### MECHANICAL DATA

Solar Cells	Poly 156.75×156.75mm (6 inches)
Cell Orientation	72 Cells (6×12)
Module Dimensions	1956×992×35mm (77 × 39.05 × 1.38 inches)
Weight	22.2 kg
Glass	High transparency solar glass 3.2mm (0.13 inches)
Backsheet	White
Frame	Silver, anodized aluminium alloy
J-Box	IP68 Rated
Cables	4.0mm <sup>2</sup> (0.006 inches <sup>2</sup> ), 1200mm (47.2 inches)
Connector	MC4 ( or other connector in CDF)
Wind Load/ Snow Load	2400Pa/5400Pa*

\*For more details please check the installation manual of GCLSI

### TEMPERATURE RATINGS

Nominal Operating Cell Temperature (NOCT)	45 ± 2°C
Temperature Coefficient of $P_{MAX}$	-0.39%/°C
Temperature Coefficient of $V_{oc}$	-0.30%/°C
Temperature Coefficient of $I_{sc}$	+0.050%/°C

### MAXIMUM RATINGS

Operational Temperature	-40 ~ +85°C
Maximum System Voltage	1000V DC(IEC)
Max Series Fuse Rating	15A

### WARRANTY

- 10 years Product Workmanship Warranty
- 25 years Linear Power Warranty

(Please refer to GCL standard warranty for details)

### PACKAGING CONFIGURATION

- Modules per box: 30 pieces
- Modules per 40'HD container: 720 pieces

### I-V CURVES OF MODULE(330W)

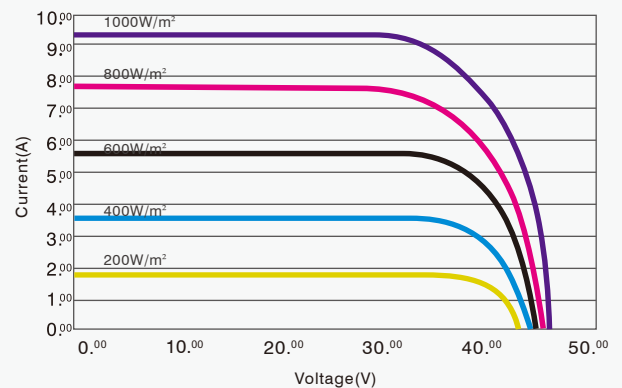

Excellent performance under weak light conditions: at an irradiance intensity of 200W/m<sup>2</sup> W/m(AM 1.5, 25 °C), 96.5% or higher of the STC efficiency (1000 W/m<sup>2</sup>) is achieved

Modules are assembled in China and Vietnam.

Factory1: Jiangsu Ds Photovoltaic Technology Co., Ltd.  
Address: No.6 Konggang New District, Guozhuang Town, Jurong, 212434 Jiangsu Province, P. R. China

Factory2: Zhangjiagang GCL System Integration Technology Co.,Ltd.  
Address: 288# Chenfeng Road, Yangshe Town, Zhangjiagang City, 215600 Jiangsu Province, P. R. China

Factory3: VINA SOLAR TECHNOLOGY CO., LTD  
Address: lot CN-03 Factory E12, Van Trung Industrial Park Bac Giang Province, Viet Nam

Factory4: Jinzhai GCL System Integration Technology Development Co., Ltd.  
Address: East of Baimafeng Road, Modern Industrial Park, Jinzhai county, Anhui Province, P.R.China

Factory5: Funing GCL System Integration Technology Co., Ltd.  
Address: No. 888(A) Hong Kong Road, Funing Economic Development Zone, Yangcheng City, Jiangsu Province P.R. China



Bringing Green Power to Life  
<http://en.gclsi.com>

GCL-EN-P6/72-2017-V4.2

CAUTION: READ INSTALLATION MANUAL BEFORE USING THE PRODUCT

©2016 GCL System Integration Technology Co., Ltd. All rights reserved. Specifications included in this datasheet are subject to change without notice.

Manufacturer Address: 288# ChenFeng Road, ZhangJiaGang E&T Deve. Zone, SuZhou, JiangSu, China