

# GCL-P6/60xxx

HIGH EFFICIENCY  
 MULTICRYSTALLINE MODULE

**GCL-P6/60 260-285 Watt**



**285<sup>W</sup>**  
 (±3%)  
 MAXIMUM POWER OUTPUT

**17.5%**  
 MAXIMUM MODULE EFFICIENCY

## Trust GCL to Deliver Reliable Performance Over Time

- World-class manufacturer of crystalline silicon photovoltaic modules
- Fully automatic facility and world-class technology
- Rigorous quality control to meet the highest standard:  
 ISO9001:2008, ISO 14001: 2004 and OHSAS: 18001 2007
- Long term reliability tests
- 2\*100% EL inspection ensuring defect-free modules

## LINEAR PERFORMANCE WARRANTY

10 Years Product Warranty    25 Years Linear Power Warranty

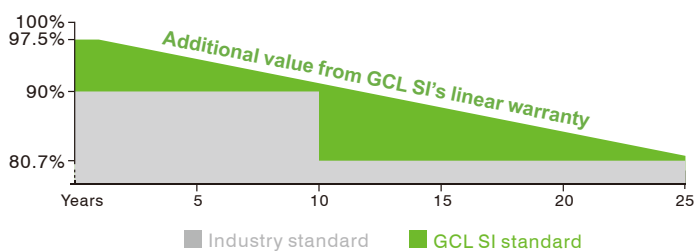

- Ideal choice for large scale ground installation
- High conversion efficiency due to top quality wafer and advanced cell technology
- Optimized system performance by module level current sorting
- Special cell process ensures great performance in low irradiance environment
- Additional yield and easy maintenance with high transparent self-cleaning glass

Additional insurance backed by Swiss RE



**Bringing Green Power to Life**

# GCL-P6/60xxx

HIGH EFFICIENCY MULTICRYSTALLINE MODULE

## MODULE DIMENSION

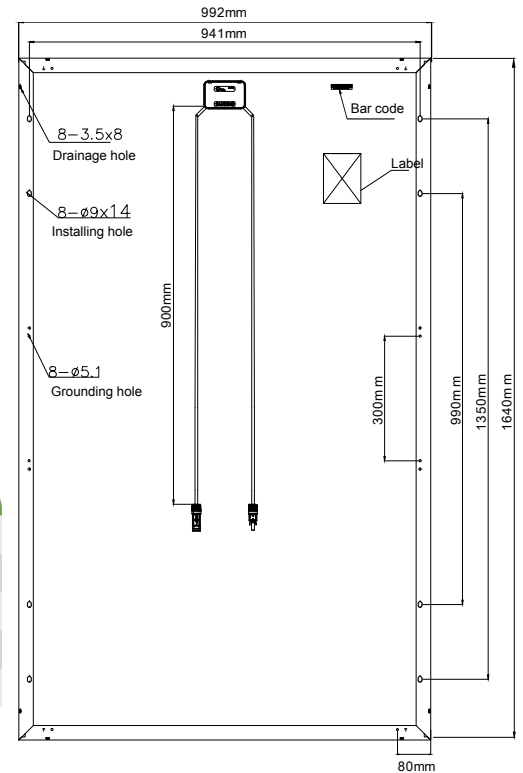

Back View

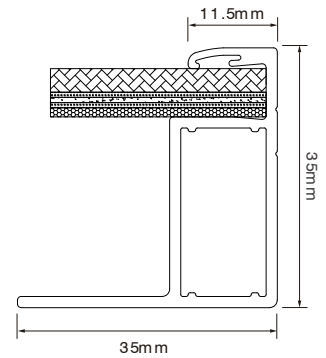

A-A

### ELECTRICAL SPECIFICATION (STC)

TYPE (STC)	GCL-P6/60 260	GCL-P6/60 265	GCL-P6/60 270	GCL-P6/60 275	GCL-P6/60 280	GCL-P6/60 285
Maximum Power P <sub>max</sub> (W)	260(±3%)	265(±3%)	270(±3%)	275(±3%)	280(±3%)	285(±3%)
Maximum Power Voltage V <sub>m</sub> (V)	30.80	31.00	31.20	31.40	31.60	31.80
Maximum Power Current I <sub>m</sub> (A)	8.44	8.55	8.65	8.76	8.86	8.96
Open Circuit Voltage V <sub>oc</sub> (V)	37.90(±3%)	38.10(±3%)	38.30(±3%)	38.50(±3%)	38.70(±3%)	38.90(±3%)
Short Circuit Current I <sub>sc</sub> (A)	9.09(±4%)	9.20(±4%)	9.29(±4%)	9.38(±4%)	9.46(±4%)	9.54(±4%)
Module Efficiency (%)	16.0	16.3	16.6	16.9	17.2	17.5
Power Output Tolerance P <sub>m</sub> (W)	0~+5					

Values at Standard Test Conditions STC (Air Mass AM1.5, Irradiance 1000W/m<sup>2</sup>, Cell Temperature 25°C).

### ELECTRICAL DATA (NOCT)

Maximum Power P <sub>max</sub> (W)	193.01	196.94	201.02	204.45	207.90	211.39
Maximum Power Voltage V <sub>m</sub> (V)	28.30	28.50	28.80	29.00	29.20	29.40
Maximum Power Current I <sub>m</sub> (A)	6.82	6.91	6.98	7.05	7.12	7.19
Open Circuit Voltage V <sub>oc</sub> (V)	35.20	35.40	35.60	35.80	36.00	36.10
Short Circuit Current I <sub>sc</sub> (A)	7.34	7.43	7.50	7.57	7.64	7.70

NOCT: Irradiance at 800W/m<sup>2</sup>, Ambient Temperature 20°C, Wind Speed 1m/s.

### MECHANICAL DATA

Solar Cells	Poly 156.75x156.75mm (6 inches)
Cell Orientation	60 Cells (6x10)
Module Dimensions	1640x992x35mm (64.56 x 39.05 x 1.38 inches)
Weight	18.1kg
Glass	High transparency solar glass 3.2mm (0.13 inches)
Backsheet	White
Frame	Silver, anodized aluminium alloy
J-Box	IP68 Rated
Cables	4.0mm <sup>2</sup> (0.006 inches <sup>2</sup> ), 900mm (35.4 inches)
Connector	MC4 ( or other connector in CDF)
Wind Load/ Snow Load	2400Pa/5400Pa*

\*For more details please check the installation manual of GCLSI

### TEMPERATURE RATINGS

Nominal Operating Cell Temperature (NOCT)	45 ± 2°C
Temperature Coefficient of P <sub>MAX</sub>	-0.39%/°C
Temperature Coefficient of V <sub>oc</sub>	-0.30%/°C
Temperature Coefficient of I <sub>sc</sub>	+0.050%/°C

### MAXIMUM RATINGS

Operational Temperature	-40~+85°C
Maximum System Voltage	1000V DC (IEC)
Max Series Fuse Rating	15A

### WARRANTY

- 10 years Product Workmanship Warranty
- 25 years Linear Power Warranty

(Please refer to GCL standard warranty for details)

### PACKAGING CONFIGURATION

- Modules per box: 30 pieces
- Modules per 40'HD container: 840 pieces

### I-V CURVES OF MODULE(275W)

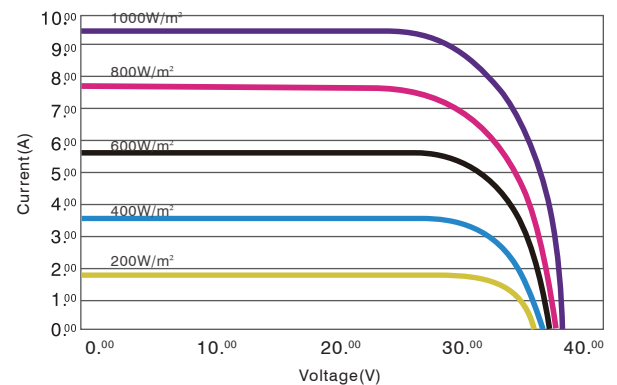

Excellent performance under weak light conditions: at an irradiance intensity of 200W/m<sup>2</sup> W/m (AM 1.5, 25 °C), 96.5% or higher of the STC efficiency (1000 W/m<sup>2</sup>) is achieved

Modules are assembled in China and Vietnam.

Factory1: Jiangsu Ds Photovoltaic Technology Co., Ltd.  
Address: No.6 Konggang New District, Guozhuang Town, Jurong, 212434 Jiangsu Province, P. R. China

Factory2: Zhangjiagang GCL System Integration Technology Co.,Ltd.  
Address: 288# Chenfeng Road, Yangshe Town, Zhangjiagang City, 215600 Jiangsu Province, P. R. China

Factory3: VINA SOLAR TECHNOLOGY CO., LTD  
Address: lot CN-03 Factory E12, Van Trung Industrial Park Bac Giang Province, Viet Nam

Factory4: Jinzhai GCL System Integration Technology Development Co., Ltd.  
Address: East of Baimafeng Road, Modern Industrial Park, Jinzhai county, Anhui Province, P.R.China

Factory5: Funing GCL System Integration Technology Co., Ltd.  
Address: No. 888(A) Hong Kong Road, Funing Economic Development Zone, Yangcheng City, Jiangsu Province P.R. China



Bringing Green Power to Life

<http://en.gclsi.com>

GCL-EN-P6/60-2017-V3.3

CAUTION: READ INSTALLATION MANUAL BEFORE USING THE PRODUCT

© 2016 GCL System Integration Technology Co., Ltd. All rights reserved. Specifications included in this datasheet are subject to change without notice.

Manufacturer Address: 288# ChenFeng Road, ZhangJiaGang E&T Deve. Zone, SuZhou, JiangSu, China