

GCL-M6/60Hxxx

HIGH EFFICIENCY
MONOCRYSTALLINE MODULE

GCL-M6/60H 285-300 Watt

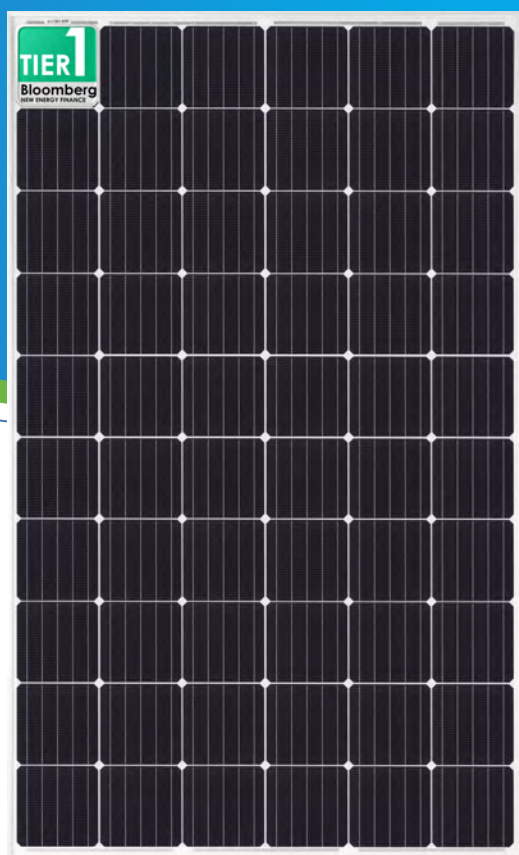

300^W
(±3%)

MAXIMUM POWER OUTPUT

18.4%

MAXIMUM MODULE EFFICIENCY

Trust GCL to Deliver Reliable Performance Over Time

- World-class manufacturer of crystalline silicon photovoltaic modules
- Fully automatic facility and world-class technology
- Rigorous quality control to meet the highest standard:
ISO9001:2008, ISO 14001: 2004 and OHSAS: 18001 2007
- Long term reliability tests
- 2*100% EL inspection ensuring defect-free modules

LINEAR PERFORMANCE WARRANTY

10 Years Product Warranty 25 Years Linear Power Warranty

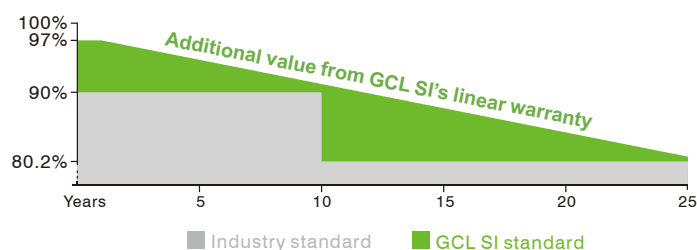

Ideal choice for large scale ground installation



High conversion efficiency due to top quality wafer and advanced cell technology



Optimized system performance by module level current sorting



Special cell process ensures great performance in low irradiance environment



Additional yield and easy maintenance with high transparent self-cleaning glass

Additional insurance backed by Swiss RE



Bringing Green Power to Life

GCL-M6/60Hxxx

HIGH EFFICIENCY MONOCRYSTALLINE MODULE

ELECTRICAL SPECIFICATION (STC)

TYPE (STC)	GCL-M6/60H 285	GCL-M6/60H 290	GCL-M6/60H 295	GCL-M6/60H 300
Maximum Power P _{max} (W)	285(±3%)	290(±3%)	295(±3%)	300(±3%)
Maximum Power Voltage V _m (V)	31.8	32.0	32.2	32.4
Maximum Power Current I _m (A)	8.96	9.06	9.16	9.26
Open Circuit Voltage V _{oc} (V)	38.9(±3%)	39.1(±3%)	39.3(±3%)	39.5(±3%)
Short Circuit Current I _{sc} (A)	9.54(±4%)	9.63(±4%)	9.69(±4%)	9.78(±4%)
Module Efficiency (%)	17.5	17.8	18.1	18.4

Values at Standard Test Conditions STC (Air Mass AM1.5, Irradiance 1000W/m², Cell Temperature 25°C).

Maximum Power P _{max} (W)	211.68	215.78	219.03	222.60
Maximum Power Voltage V _m (V)	29.4	29.6	29.8	30.0
Maximum Power Current I _m (A)	7.20	7.29	7.35	7.42
Open Circuit Voltage V _{oc} (V)	36.1	36.3	36.5	36.6
Short Circuit Current I _{sc} (A)	7.72	7.79	7.84	7.91

NOCT: Irradiance at 800W/m², Ambient Temperature 20°C, Wind Speed 1m/s.

MECHANICAL DATA

Solar Cells	Mono 156.75x156.75mm (6 inches)
Cell Orientation	60 Cells (6x10)
Module Dimensions	1640x992x35mm (64.56 x 39.05 x 1.38 inches)
Weight	18.1kg
Glass	High transparency solar glass 3.2mm (0.13 inches)
Backsheet	White
Frame	Silver, anodized aluminium alloy
J-Box	IP68 Rated
Cables	4.0mm ² (0.006 inches ²), 900mm (35.4 inches)
Connector	QC4.10-cd (or other connector in CDF)
Static mechanical load	Design load: 3600Pa (downward) / 1600Pa (upward). γ _m =1.5

TEMPERATURE RATINGS

Nominal Operating Cell Temperature (NOCT)	45 ± 2°C
Temperature Coefficient of P _{MAX}	-0.39%/°C
Temperature Coefficient of V _{oc}	-0.30%/°C
Temperature Coefficient of I _{sc}	+0.060%/°C

MAXIMUM RATINGS

Operational Temperature	-40 ~ +85°C
Maximum System Voltage	1500V DC(IEC)
Max Series Fuse Rating	15A

WARRANTY

10 years Product Workmanship Warranty
25 years Linear Power Warranty

(Please refer to GCL standard warranty for details)

PACKAGING CONFIGURATION

Modules per box: 30 pieces
Modules per 40'HD container: 840 pieces

MODULE DIMENSION

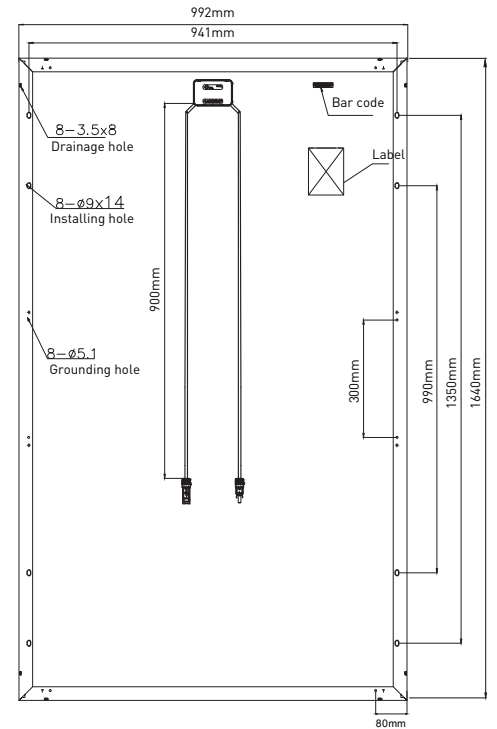

Back View

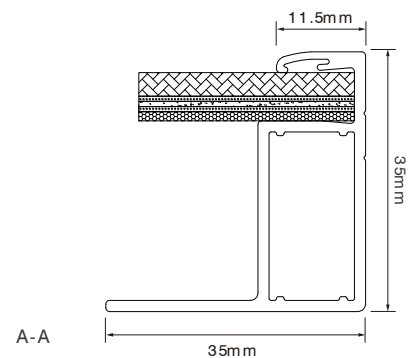

I-V CURVES OF MODULE(290W)

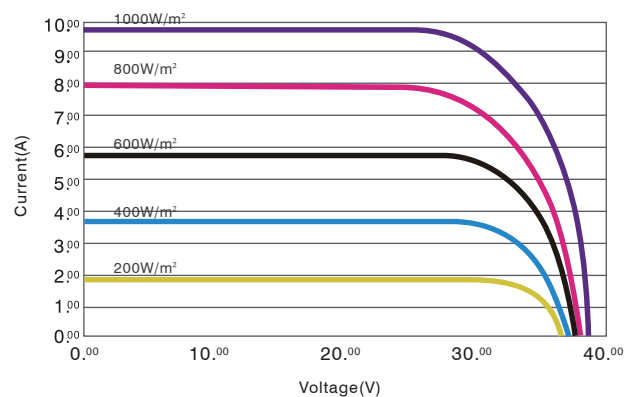

Excellent performance under weak light conditions: at an irradiance intensity of 200W/m² W/m(AM 1.5, 25 °C), 96.5% or higher of the STC efficiency (1000 W/m²) is achieved

Modules are assembled in China and Vietnam.

Factory1: Jiangsu Ds Photovoltaic Technology Co., Ltd.
Address: No.6 Konggang New District, Guozhuang Town, Jurong, 212434 Jiangsu Province, P. R. China

Factory2: Zhongjiagang GCL System Integration Technology Co., Ltd.
Address: 288# Chenfeng Road, Yangshe Town, Zhongjiagang City, 215600 Jiangsu Province, P. R. China

Factory3: VINA SOLAR TECHNOLOGY CO., LTD
Address: lot CN-03 Factory E12, Van Trung Industrial Park Bac Giang Province, Viet Nam

Factory4: Jinzhai GCL System Integration Technology Development Co., Ltd.
Address: East of Baimafeng Road, Modern Industrial Park, Jinzhai county, Anhui Province, P.R.China

Factory5: Funing GCL System Integration Technology Co., Ltd.
Address: No. 888(A) Hong Kong Road, Funing Economic Development Zone, Yangcheng City, Jiangsu Province P.R. China



Bringing Green Power to Life

<http://en.gclsi.com>

GCL-EN-M6/60H-2017-V3.1

CAUTION: READ INSTALLATION MANUAL BEFORE USING THE PRODUCT

©2016 GCL System Integration Technology Co., Ltd. All rights reserved. Specifications included in this datasheet are subject to change without notice.